

# Read and Save These Instructions



## DH70 - Crawl Space, Attic or Basement Whole House Dehumidifier Installation & Owners Manual

### Specifications

- Model: DH70
- Capacity: 70 pints/day, (3.25lbs./hr) @ 80°/60%RH
- Electrical: 110-120 VAC, 6.7 FLA Amps, 60 Hz, grounded
- Operating Return Air Temp. Range: 50°F min., 90°F max.
- Air Flow:
  - 280 CFM without external ducting
  - 235 CFM @ .30 IWG external static
  - 195 CFM @ .50 IWG external static
- Refrigerant Charge: 17.5 oz. R-410A
- Duct connections: Return duct flange: 8" Round, Outlet 8" Round,
- Filter Size: High Efficiency (MERV 11): Pleated 11-3/4" X 11-3/4" X 2"
- Size (Clearance): 14" Height x 26" Width x 14" Depth, 12" minimum front or rear clearance for filter service.
- Weight: 65 pounds (Shipping Weight 80 pounds)

*Read the installation operation and maintenance instructions carefully before installing and using this unit. Proper adherence to these instructions is essential to obtain maximum benefit from the DH70 system. Installation contrary to these guidelines or lack required maintenance will void warranty.*

### Unit Location

The DH70 can be installed in a variety of locations to meet the owner's needs as listed below. In all cases keep the following cautions in mind:

- The unit is designed to be installed indoors in a space that is protected from rain, flooding and/or other forms of excess water. Unit is not designed to be exposed to chlorinated pool conditions or spaces where unit will be exposed to corrosive chemicals or conditions.

Install the unit with space to access the front panel for maintenance and service. Also allow easy access to the filter cover panel. **DO NOT INSTALL THE UNIT WITH THE FRONT PANEL OR FILTER COVER PANEL INACCESSIBLE.**

- Avoid discharging the air directly at people, over the water in pool areas, or other areas or objects where dehydration or evaporation of moisture is not desired.
- If used near wet areas, be certain there is NO chance the unit could fall into the water or be splashed and that it is wired into a GROUND FAULT INTERRUPTER protected circuit (see local codes for other requirements).
- A secondary drain pan **MUST** be placed under the unit if installed above a living area or above an area where water leakage could cause damage (see local codes for other requirements).
- **DO NOT** locate the DH70 directly on structural members where noise or vibration may be objectionable. The DH70 is equipped with adjustable support feet to raise and level the unit from the mounting surface, these adjustable feet should be utilized to provide improved drainage from the drain pan and should be adjusted to tilt slightly toward the drain utilized.

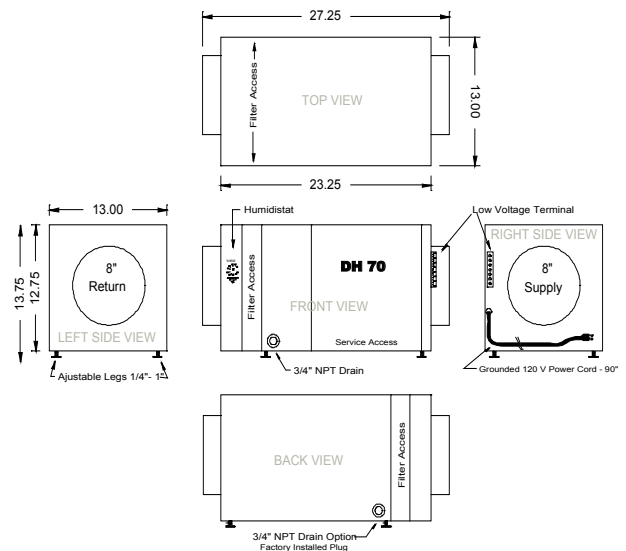

- In a whole house system, the DH70 should be located near the existing air handling system to minimize the required ductwork for connecting of the DH70 system. When the remote control option is used, the control (humidistat) unit must be located in the space that is to be conditioned. The control (humidistat) may be low voltage (24 volt) and should be connected to the DH70 with code approved, low voltage thermostat cable.
- **When a remote Humidistat is utilized, set the unit mounted humidistat to the “OFF” position.**
- When locating the DH70 in areas of extreme heat or high humidity, >120-degrees/90% humidity, additional external insulation may be required to prevent undesired condensation on the exterior of the unit.

## Electrical Requirements

- The DH70 are equipped with an appliance cord with ground prong and may be plugged directly into a grounded 3 prong, 120 volt, 15 amp household type convenience outlet. If used in a wet area such as an indoor pool, spa room, or an area prone to flooding (basement or crawlspace), a ground fault interrupter protected circuit is required. In all cases local codes precede over all installation and wiring recommendations.
- **Do not remove ground prong. Do not use an adaptor. Do not use an extension cord.**
- If a remote wall mounted Humidistat is utilized, install the Humidistat control in a central area of the structure where it will sense the relative humidity of the structure accurately. Do not install the control where it may not accurately sense the relative humidity: near HVAC supply registers, near exterior doors, or near a pool or spa. Do not install the control in an area not served by the DH70. The installer must supply the wiring between the DH70 and the Humidistat control. Be sure to safely route the control wiring to prevent damage during installation. Be careful not to cross the wires when connecting the DH70 and the control or damage to the transformer may result.
- **When a remote Humidistat is utilized, set the unit mounted humidistat to the “OFF” position.**
- Consult the electrical schematic in this manual or inside the access panel of the DH70 before making the control connections.

## Condensate Removal

Condensate drains by gravity, via the ¾” PVC drain outlet located at two locations, front side and back side. Use of both is not required. As shipped the rear drain is plugged, and may be removed and replaced into the front drain outlet if the rear outlet is used. Also included with the unit is the condensate drain trap, this trap must be used to allow the unit to drain properly during operation and prevent air from being drawn from the area where the unit is located. An optional condensate pump kit may be installed if a lift is required to dispose of the condensate. If an optional pump is used the condensate trap is still necessary and must be installed between the unit and pump. When the condensate drain is located in, or passes through, a non-conditioned space, the condensate piping should be insulated to prevent the drain line sweating that may cause damage.

**Avoid double trapping.** Where flexible tubing is used, or the possibilities of sags occurring in the drain line exist, or the drain terminates in a sump below the waterline, the drain must be vented to allow proper draining. A condensate drain vent must be installed at the outlet side of the drain trap, between the trap and the balance of drain line.

## Ducting (See Ducting Diagram)

### A. Installing Duct

The DH70 is equipped with an 8”round duct collar inlet, and an 8” round exhaust/supply collar that provides for connecting to the supply distribution system. In all cases sound duct design practices must be followed such as those provided in ACCA manual “D”, or ASHRAE’s “Fundamentals of Air System design”.

## B. Ducting for Dehumidification

For the ideal installation, draw air from the central part of the home and return it to the isolated areas of the home like the bedrooms, den, utility room, or family room. The ductwork of the existing HVAC system can be used to supply air to the home. If the existing supply duct adequately serves all areas of the home, discharge the supply air of the DH70 into the return of the existing HVAC system where it can be distributed throughout the space. The existing return duct, if adequate, may be used as return for the DH70, **DO NOT** draw air directly from the kitchen, laundry, or isolated basement. You may draw air from a basement that is open to the home. All flexible ducting connected to the DH70 should be approved by local codes and in most cases insulated.

- Return air ducts should be designed to allow unimpeded air flow to the return side of the system. For returns less than 10' in length, an 8" round or equal may be utilized. Multiple returns are acceptable.
- The supply air outlet and the return air inlet are located on each end of the DH70. A length of acoustical flex ducting on the outlet of the DH70 will reduce air noise. A length of flexible ducting on all DH70 duct connections is recommended to reduce noise and vibration transmitted to rigid ductwork in the structure.
- Ducting the DH70 as mentioned in the "Ducting" sections requires consideration of the following points:
  - Duct Sizing: For total duct lengths up to 10', use a minimum 8" diameter round or equivalent rectangular. For longer lengths, up to 25', use a minimum 10" diameter or equivalent duct size. Grills or diffusers utilized must not excessively restrict airflow.
  - Isolated Areas: Effective dehumidification may require that ducting be branched to isolated, stagnant areas. Use 8" or larger diameter branch ducting to each of two or three areas, use 6" or larger to each of four or more areas.

Connecting to Existing HVAC Systems: For proper operation, connecting to existing air handler and duct systems requires the fans of each system to be interlocked utilizing the low voltage interlock method provided in the DH70 low voltage connection diagram. Refer to low voltage connection diagram in this document and on the unit.

## C. Installation in a Basement or Crawl Space with an Existing Forced Air HVAC System (Whole House Dehumidification)

If the structure in which the DH70 System is to be installed has an existing forced air HVAC system, and this system serves the areas that are desired to be controlled, utilize the HVAC system to make the DH70 System installation easier and provide better whole house type system performance.

**Basement or Crawl Space Installation:** Install a separate 8" return for the DH70 in a central area of the structure or if the return ducting is adequate tap into the existing return duct system near the return air grill. Duct the supply of the DH70 System to the return ducting of the existing HVAC system. The fan interlock provision must be utilized for proper system performance.

## D. Installation in an Attic with an Existing Forced Air HVAC System (Whole House Dehumidification)

**ALWAYS** install a secondary drain pan with a drain or float interrupt for condensation under the DH70 in an attic to prevent condensate overflow that may drip down damaging the ceiling or living space below.

Install a separate 8" return for the DH70 in a central area of the structure or if the return ducting is adequate tap into the existing return duct system near the return air grill. Duct the supply of the DH70 System to the return ducting of the existing HVAC system. The fan interlock provision must be utilized for proper system performance.

## E. Installation in a Structure with Two Forced Air HVAC Systems (Whole House Dehumidification)

Attach the DH70 return to an independent return from the upper level. Attach the DH70 supply to the return of the basement HVAC system. This will promote circulation of air through the whole structure from the upper level to the lower level through the DH70. If the DH70 is not connected to both HVAC systems, it may not control the humidity of the entire structure. The fan interlock provision should be connected to the lower, ducted, HVAC system and must be utilized for proper system performance.

## F. Installation in a Structure with No Existing Forced Air HVAC System (Whole House Dehumidification)

When installing the DH70 in a structure that does not have a forced air HVAC system, a single return for the DH70 should be installed in central open area of the structure. **DO NOT** locate the return in a bathroom or a kitchen. The supply of the DH70 should be located in the remote areas of the structure (such as bedrooms, den, etc.). By ducting this way, the air inside the structure will circulate through the DH70 to be filtered and dehumidified. 5" diameter duct is recommended for branches to the bedrooms, 6" diameter duct is recommended for branches to larger areas.

## G. Installation in a Sealed Crawl Space or Sealed Attic (Spot Dehumidification)

When installing the DH70 in sealed crawlspace or sealed attic, a single return for the DH70 should be installed in central open area of the structure. If the area is open without partitions return ducting is not necessary. Supply ducting is recommended to enhance the performance of the system, a minimum length of supply duct, 3' to 6' will aid in air distribution. If the area(s) being served are divided by walls or partitions, a supply and return duct system is recommended. In all cases sound duct design practices must be followed such as those provided in ACCA manual "D", or ASHRAE's "Fundamentals of Air System Design".

## Wiring Unit Schematic

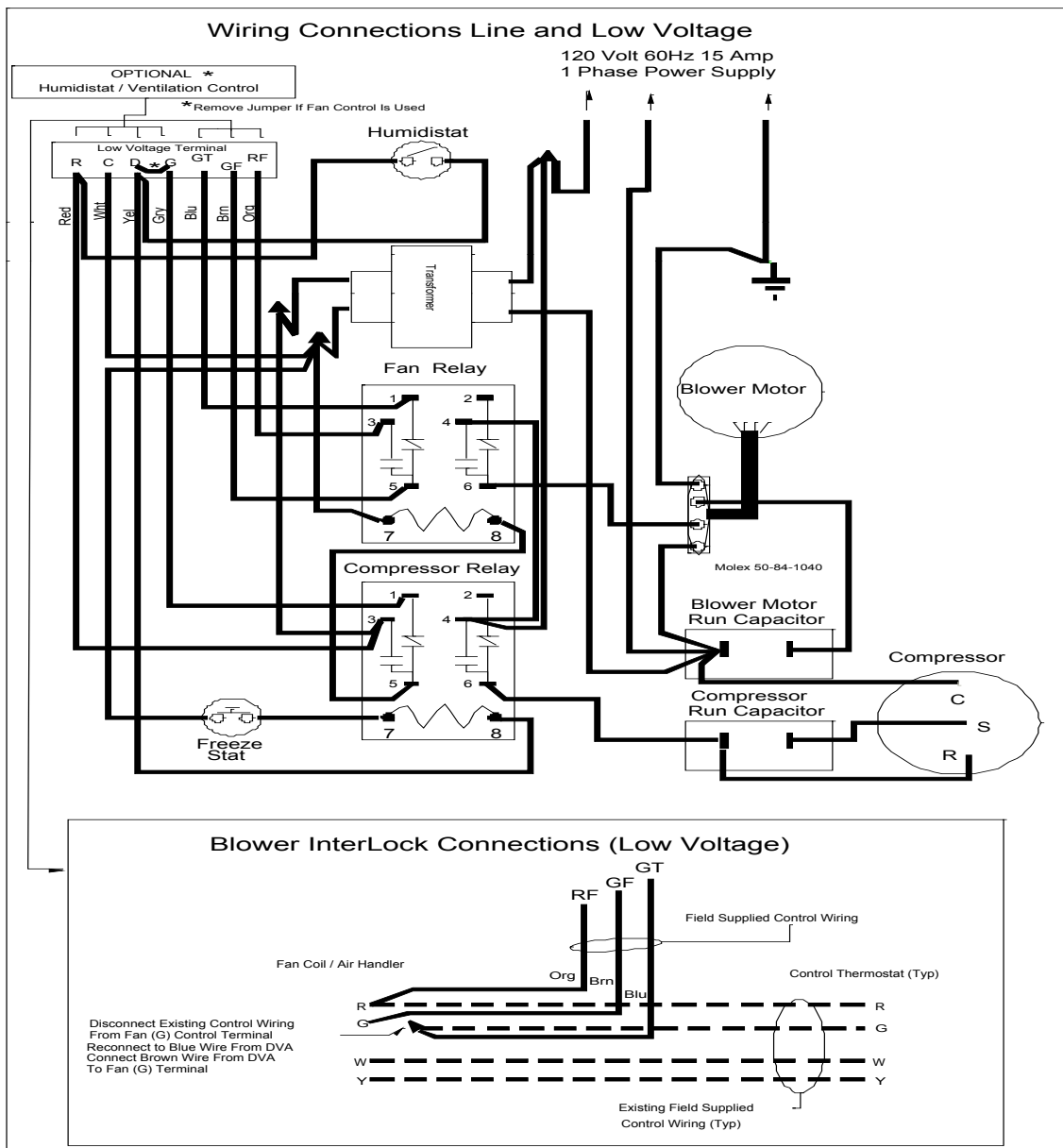

## Field Connections, Low Voltage

When a remote Humidistat is utilized, set the unit mounted humidistat to the “OFF” position.

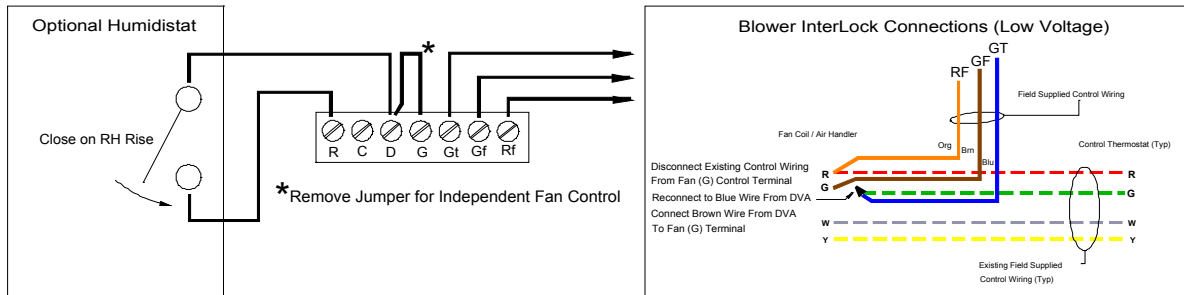

## Typical Equipment Layout Specification & Duct Connection

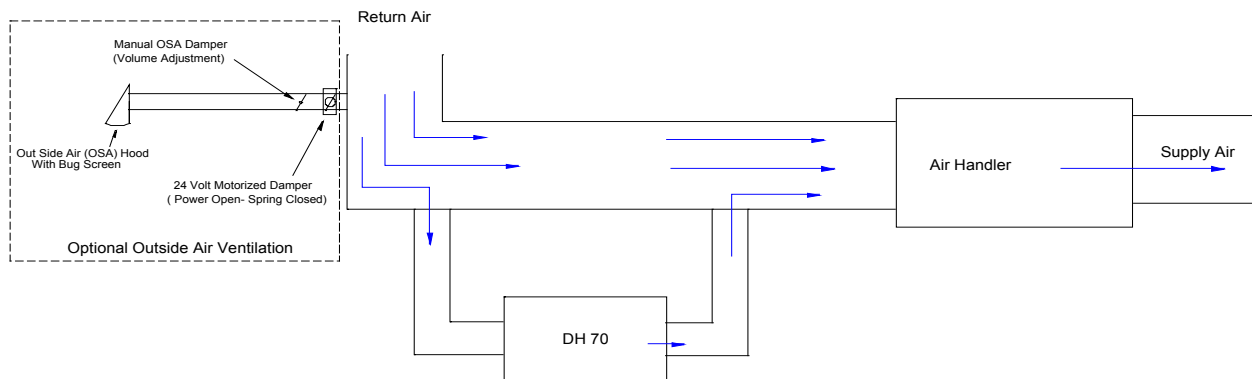

## Operation

The DH70 is designed to deliver dehumidified, filtered air to the living space, and is equipped with an onboard humidistat and fan control and can be equipped with various accessories to enhance its operation, including a remote humidistat, and your system may incorporate any or all of the described operational components

It is recommended that the indoor environment maintain a maximum relative humidity level of 50% to 60%. Other factors may dictate a relative humidity level different than the recommended, such as musical instruments, antiques, books/papers, or special situations. Winter minimum humidity levels of 30-35% may not be attainable without supplemental humidification (Humidifier), and may not be desired during times of low outdoor temperatures.

### System Variations:

#### Humidity Control - Standard

The system may be installed as free standing or incorporate ducting to an area or existing heating/cooling system. Control is provided by Humidistat with a dial stem type adjustment built into the unit. Set the desired humidity set point by turning the dial stem flat to the corresponding set point indicated on the face of the unit. This humidity control unit will operate the compressor and circulation fan when the dehumidification system is activated, working only when there is a call, or demand for dehumidification.

#### Remote Humidity Control (Wall Mounted)

When a remote Humidistat is utilized, set the unit mounted humidistat to the “OFF” position.

This control provides the same control functions as above but with greater precision and can be located in the space for easier access, and may include additional features. Available as an accessory item these controls may have different features; refer to instructions included with the control.

## Typical System Operation Sequence

Upon the relative humidity exceeding the humidistat set point, normally by approximately 3%, the humidistat will energize the dehumidification and air circulation components of the DH70 (note the time delay on some electronic humidistats). If the DH70 system is connected and interlocked with an existing Heating/Air conditioning system, this systems circulation fan will also be energized. The DH70 will continue to operate until the humidity level is reduced to the set point selected on the humidistat and then will cycle off. During this cycle, the air circulated through the DH70 system will be filtered and dehumidified. If an outside ventilation air duct has been installed, fresh air will be filtered and dehumidified and introduced to the space during this cycle.

## Coil Freeze Protection (Auto Defrost)

### Maintenance

#### High Efficiency Air Filter

The DH70 is supplied with a 2" pleated high efficiency air filter. The 2" filter is rated MERV 11, and is more efficient than standard air filters and is able to catch much smaller particles that can aggravate allergies. Operating the unit with a dirty filter will reduce dehumidifier capacity and efficiency and may cause the compressor to cycle off and on unnecessarily. Under normal operating conditions, the filter will last approximately 6 months. However, in high particulate concentrations more frequent replacements may be required. It is recommended that the filter be inspected regularly for the first three to four months to determine the loading and correct replacement intervals. Your installation contractor should be contacted for assistance.

To access the air filter, remove the filter access panel from the Front or Back side of the unit, marked "Filter Access". The filter should be readily visible and can be removed by pulling it straight out of the unit.

Replacement filters can be purchased from your installation contractor or ordered from the factory if a local representative is not available. **DO NOT** operate the unit without the filter, or with a less effective filter than originally supplied. The heat exchange coils inside the unit could become clogged and require disassembly to clean. **FAILURE TO MAINTAIN SERVICE AND UTILIZE CLEAN FILTERS WILL VOID WARRANTY.**

#### Oiling & Lubrication

The fan motor is factory lubricated and sealed, and no further oiling is required. There are no other components requiring the addition of lubricants.

#### Optional Fresh Air Ventilation (OSA)

If your system includes the optional fresh air system, it will have an outside air intake. Check and clean the screen on the outdoor fresh air intake seasonally. The intake screen must remain clear of any debris that could restrict airflow into the system. This intake should never be located where undesirable fumes, gases or odors make be taken up by the intake. In all cases local codes prevail as to the location of fresh air intakes.

# Limited Warranty

Applies in U.S.A. and Canada Only

## **FAILURE TO MAINTAIN YOUR EQUIPMENT WILL VOID THIS WARRANTY**

### **COVERED EQUIPMENT**

The following General Filters, Inc. equipment is covered by the Limited Warranty:

**Whole House Dehumidifier Units:** DH70 (“Covered Equipment”)

### **TWO (2) YEARS COVERAGE - RESIDENTIAL APPLICATIONS**

DH70 Parts warranted by General Filters, Inc. (“Company”) for a period of two (2) years from the date of the original installation, when installed in residential applications (“Limited Warranty Period”).

### **“EXTENDED COVERAGE EQUIPMENT”: COMPRESSORS**

DH70 - Five (5) Years. Compressor warranty is five (5) years from the date of the original installation in all residential applications (“Extended Warranty Period”). (Note, commercial applications warranty is 2 years.)

### **EXCLUDED COMPONENTS**

The following components are not covered by this warranty: cabinets, cabinet pieces, air filters, driers, refrigerant, refrigerant line sets, wiring, fuses, and unit accessories.

### **CARE OF EQUIPMENT**

The Covered Equipment must be properly installed, operated and maintained in accordance with the installation, operation and maintenance instructions provided with each unit of Covered Equipment. Failure to provide maintenance according to Company’s instructions will void this Limited Warranty. Owner may be asked to provide written documentation of annual and other periodic preventive maintenance.

### **WARRANTY TERMS**

This Limited Warranty is valid only for the original customer purchasing from Company or an authorized reseller (“Owner”), subject to proof of purchase and not transferable. This Limited Warranty will be null and void upon attempted assignment or transfer. If during the Limited or Extended Warranty Period, Covered or Extended Coverage Equipment fails because of a manufacturing defect, Company will provide a free replacement part to the Owner through a licensed service contractor. All repairs of Covered and Extended Coverage Equipment must be made with authorized service parts by a licensed service dealer or contractor. Owner must pay shipping charges and all other costs of Limited Warranty service. Company will not pay labor involved in diagnostic calls or in removing, repairing, servicing or replacing parts. Such costs may be covered by a separate warranty provided by the installer. This Limited Warranty does not cover any costs related to changes to Covered or Extended Coverage Equipment that may be required by any codes, laws, or regulations that may become effective after initial purchase of the same by Owner. NOTE: If the date of original installation cannot be verified, the warranty period will be deemed to begin one (1) months after the date of manufacture.

### **CUSTOMER RESPONSIBILITIES**

As a further condition to obtaining Limited Warranty coverage hereunder, Owner must provide a valid warranty claim to Company such that Company receives such claim prior to the end of the applicable Limited or Extended Warranty Period. Company shall have no obligation hereunder with respect to any claim received by Company after the expiration of the applicable Limited or Extended Warranty Period. As a further condition to obtaining limited warranty coverage hereunder, the Owner must present forms of invoices evidencing proof of purchase and installation of Covered Equipment. **The Owner must complete our online Returns Form ([www.generalfilters.com/returns](http://www.generalfilters.com/returns)), to arrange for applicable Limited Warranty service.** Limited Warranty service will be performed during customary, daytime working hours. If the Covered or Extended Coverage Equipment must be shipped for service, Owner shall be solely responsible for properly packaging the Covered or Extended Coverage Equipment, for all freight charges, and for all risk of loss associated with shipment. Owner must also provide complete model and serial number, proof of required periodic maintenance, installation date and location and an accurate description of the problem.

### **WARRANTY LIMITATIONS**

1. This Limited Warranty is void if the Covered or Extended Coverage Equipment is removed from the original installation site.
2. This Limited Warranty does not cover damage or defect resulting from:
  - Flood, wind, fire, lightning, mold, or installation and operation in a corrosive atmosphere, or otherwise in contact with corrosive materials (chlorine, fluorine, salt, recycled waste water, urine, fertilizers, or other damaging substances or chemicals)
  - Accident or neglect or unreasonable use or operation of the equipment including operation of electrical equipment at voltages other than the range specified on the unit nameplate (includes damages caused by brownouts)
  - Modification, change or alteration of the equipment, except as directed in writing by Company
  - Operation with system components (indoor unit, outdoor unit and refrigerant control devices) which do not match or meet the specifications recommended by Company
  - Use of contaminated or alternate refrigerant
3. The installation of replacement parts under the terms of this Limited Warranty does not extend the original Limited or Extended Warranty Period.

## LIMITATIONS OF REMEDIES

OWNER'S SOLE AND EXCLUSIVE REMEDY UNDER THE ABOVE LIMITED WARRANTY AND COMPANY'S ENTIRE LIABILITY THEREUNDER, SHALL BE, AT THE SOLE OPTION OF COMPANY, REPLACEMENT OR REPAIR OF SUCH COVERED OR EXTENDED COVERAGE EQUIPMENT AND ITS COMPONENTS ("COMPONENTS") BY COMPANY OR COMPANY'S AGENTS ONLY. REFRIGERANT, PIPING, SUPPLIES, TRANSPORTATION COSTS, LABOR COSTS INCURRED IN REPAIR OR REPLACEMENT OF SUCH COMPONENTS ARE NOT INCLUDED. THIS DISCLAIMER AND EXCLUSION SHALL APPLY EVEN IF THE EXPRESS LIMITED WARRANTY AND LIMITED REMEDY SET FORTH HEREIN FAILS OF ITS ESSENTIAL PURPOSE. OWNER ACKNOWLEDGES THAT NO REPRESENTATIVE OF COMPANY OR OF ITS AFFILIATES OR RESELLERS IS AUTHORIZED TO MAKE ANY REPRESENTATION OR WARRANTY ON BEHALF OF COMPANY OR ANY OF ITS AFFILIATES OR RESELLERS THAT IS NOT IN THIS AGREEMENT.

## LIMITATIONS OF LIABILITY

General Filters, Inc. makes no express warranties other than the warranty specified above. All implied warranties, including the implied warranties of merchantability and fitness for a particular purpose, are excluded to the extent and for a period legally permissible. Should such exclusion or limitation of the warranty be unenforceable, such implied warranties are in any event limited to a period of one (1) year. Liability for special, incidental, direct, indirect, collateral and consequential damages is excluded. Some states do not allow limitation of incidental damages, so the limitations or exclusions may not apply to you. General Filters, Inc. will not pay electricity or fuel costs, or increases in electricity or fuel costs, for any reason whatsoever, including additional or unusual use of supplemental electric heat. This warranty does not cover lodging expenses or labor charges. General Filters, Inc. shall not be liable for any default or delay in performance under this warranty caused by any contingency beyond its control. This warranty gives you specific legal rights, and you may also have other rights which vary from state to state.

## APPLICABLE LAW AND VENUE

ANY ARBITRATION, ENFORCEMENT OF AN ARBITRATION OR LITIGATION RELATED TO THE PRODUCT WILL BE BROUGHT EXCLUSIVELY IN OAKLAND COUNTY, STATE OF MICHIGAN, AND CUSTOMER CONSENTS TO THE JURISDICTION OF THE FEDERAL AND STATE COURTS LOCATED THEREIN, SUBMITS TO THE JURISDICTION THEREOF AND WAIVES THE RIGHT TO CHANGE VENUE. CUSTOMER FURTHER CONSENTS TO THE EXERCISE OF PERSONAL JURISDICTION BY ANY SUCH COURT WITH RESPECT TO ANY SUCH PROCEEDING. If any term or condition of this Limited Warranty is found by a court of competent jurisdiction to be invalid, illegal or otherwise unenforceable, the same shall not affect the other terms or conditions hereof or thereof or the whole of this Limited Warranty. Any delay or failure by Company to exercise any right or remedy will not constitute a waiver of Company to thereafter enforce such rights

Keep this warranty and your sales slip together for future reference. You must provide proof of purchase or installation date for in-warranty service.

Write down the following information about your Dehumidifier to better help you obtain assistance or service if you ever need it. You will need to know the complete model and serial number. You can find this information located on the rating plate on the outside panel for all models.

Unit Model Number \_\_\_\_\_

Serial Number \_\_\_\_\_

Installation Date \_\_\_\_\_

Installing Contractor Phone \_\_\_\_\_

*Cut Along Dashed Line*

## WARRANTY REGISTRATION

You may register online at [www.GeneralAire.com](http://www.GeneralAire.com) or mail form below

### Product Information:

Serial Number: \_\_\_\_\_

Model: \_\_\_\_\_

Install Date:      Month \_\_\_\_\_ Day \_\_\_\_\_ Year \_\_\_\_\_



### Owner Information:

Name: \_\_\_\_\_

Address: \_\_\_\_\_

Address 2: \_\_\_\_\_

City: \_\_\_\_\_ State: \_\_\_\_\_ Zip Code: \_\_\_\_\_

Phone: \_\_\_\_\_

Email: \_\_\_\_\_

Mail Form To:  
General Filters, Inc  
Attn: Warranty Dept.  
43800 Grand River Ave.  
Novi, MI 48375

### Contractor Information:

Contractor Name: \_\_\_\_\_

Address: \_\_\_\_\_

Address 2: \_\_\_\_\_

City: \_\_\_\_\_ State: \_\_\_\_\_ Zip Code: \_\_\_\_\_

Contractor Phone: \_\_\_\_\_

Contractor Email: \_\_\_\_\_